

GUARDIAN



TQ-DONOR- 698-960-8 Wide Band Yagi Donor Antenna



FEATURES

- Wide Band (698 – 2700 MHz)
- Directional antenna – designed to be pointed directly at the radio tower
- 8 dBi Gain
- Designed for outdoor use only

The TQ-DONOR-698-960-8 is an outdoor yagi antenna that can be aimed in the direction of the closest radio tower and pick up signals up to 5 miles away. The wide band yagi antenna is designed to cover 800MHz and 700MHz frequencies.

When installing, any metallic rods must be at least 3 feet from the antenna. Mount the entire assembly to a 1 to 2 inch diameter pole (not included).

In addition to the antenna, mounting equipment is included for mounting to either a flat horizontal surface or wall. For best results, the white fiber-glass portion of the antenna should be mounted above the roof line and unobstructed in the direction of the tower.

Technical Specifications

Frequency	698-806 / 806-960 / 1710-2700 MHz
Input Impedance	50 ohm
Antenna Gain	8 dBi
VSWR	≤1.8
Polarization Type	Vertical
Radiation	Directional
Maximum Power	50 Watt
Connector Type	N-Female
Diameter	Φ40~50
Dimension	17.3" x 8" x 1.45"
Color	White
Weight	2 lb 4 oz
Beamwidth	E50 H75 / E50 H75 / E40 H60

GUARDIAN

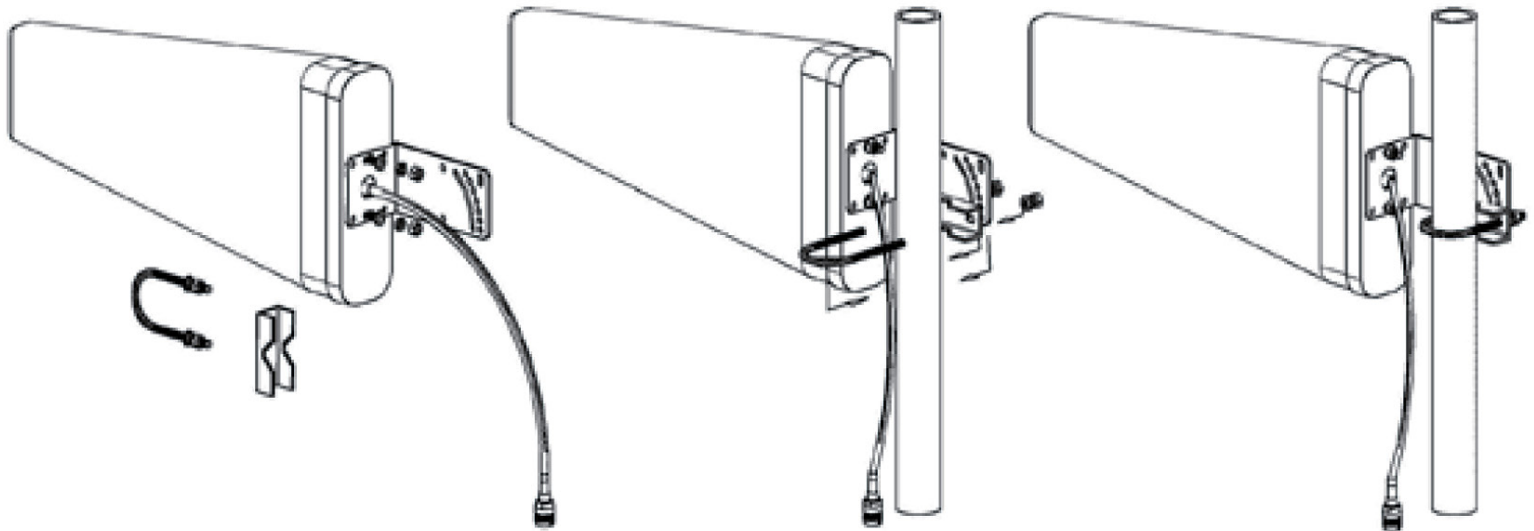

Installation

1. Install U-Bolt on pole
2. Slide pipe clamp over U-Bolt with the flat side facing away from the pipe.
3. Slide antenna bracket onto U-Bolt in desired location.
4. Install flat washer, split washer and nut, hand tighten

Note: Antenna may be installed on a variety of pipe angles. Ensure that the antenna is pointing in the direction of the closest cellular tower, and is vertical with the drip hole at the bottom.

Ordering Information

Model	Description	Stock No.
TQ-DONOR-698-960-8	Outdoor, Yagi Directional Antenna 50 ohm, 8 dBi, 698-960MHz, 50W	3996048